



# Power Transformation Units

2-Wheel, 4 Wheel E-Cart® Catalog



[ericson.com](http://ericson.com)

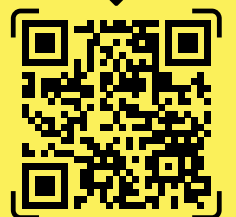

EXPERIENCE. INNOVATION. EXPERTISE.

# Power Transformation Units 2-Wheel & 4-Wheel Carts

## Table of Contents

If viewing the digital catalog, click on a page to directly take you there.

About Ericson	Page 3
How it all works together.	Page 4
2-Wheel Carts	Page 5
Open 2 Wheel	Page 5-8
Cage 2 Wheel	Page 9-12
4-Wheel Carts	Page 12
Open 4-Wheel Carts	Page 12-14
Cage & Enclosed 4-Wheel Carts	Page 15-18
T-Frame	Page 19-20
Part Number Nomenclature	Page 21
High kVA Stackable Steel Cage Frame Design	Page 22
Entertainment Steel, Stackable, Cage Frame Design	Page 23
Hazardous Location Stackable, Steel Cage Frame Design	Page 24-25
Design Your Own e-Cart™	Page 26-30
Specific Application Designs	Page 31-33
Related Products	Page 34
Notes	Page 35



Go to [Ericson.com](https://www.ericson.com), and at the search bar  enter your part number for an Ericson cross or contact our applications team at **1-800-ERICSON. (374-4266)**



# About Ericson Manufacturing

Founded in 1918 with over a century of innovation, experience and expertise has given Ericson the unique opportunity to offer the industry a comprehensive line of products, designed with exceptional worker safety in mind. Robust design and precision manufacturing set Ericson apart for quality products offering exceptionally long service life.

Ericson prides itself on building over 98% of it's products in the North America, giving our customers a reliable and secure supply line.

Our custom engineered products are designed to meet critical customer requirements for their most challenging applications and exceed their expectations, for highly engineered quality built products.

Thank you for considering Ericson Manufacturing products.



# How it works *together.*

For over **100 years**, Ericson has designed and engineered innovative products with a keen focus on worker safety. With decades of experience developing robust products for the most demanding applications, Ericson products deliver value through their exceptionally long service life and safety. Below is an illustration of how Ericson products All Work Together to deliver safe, reliable power and lighting to critical temporary applications.

## ① Jobsite Power

### PTU

Power Transformation Units convert 480V or 600V power, to lower voltages used for portable tools and lighting.

## ② Jobsite Power

### PDU

Power Distribution Unit provide local power with overload, open neutral protection and GFCI protection for 120, 240, or 208V receptacles.

## ③ Jobsite Lighting

### Lighting

Ericson provides a myriad of lighting solutions, from stringlights and baylights to handlamps and hazardous area fixtures.

## ④ Portable Power

### Cordsets

Factory assembled solutions provide safe, reliable NEC, and OSHA Code Compliant GFCI & AEGCP cordsets.

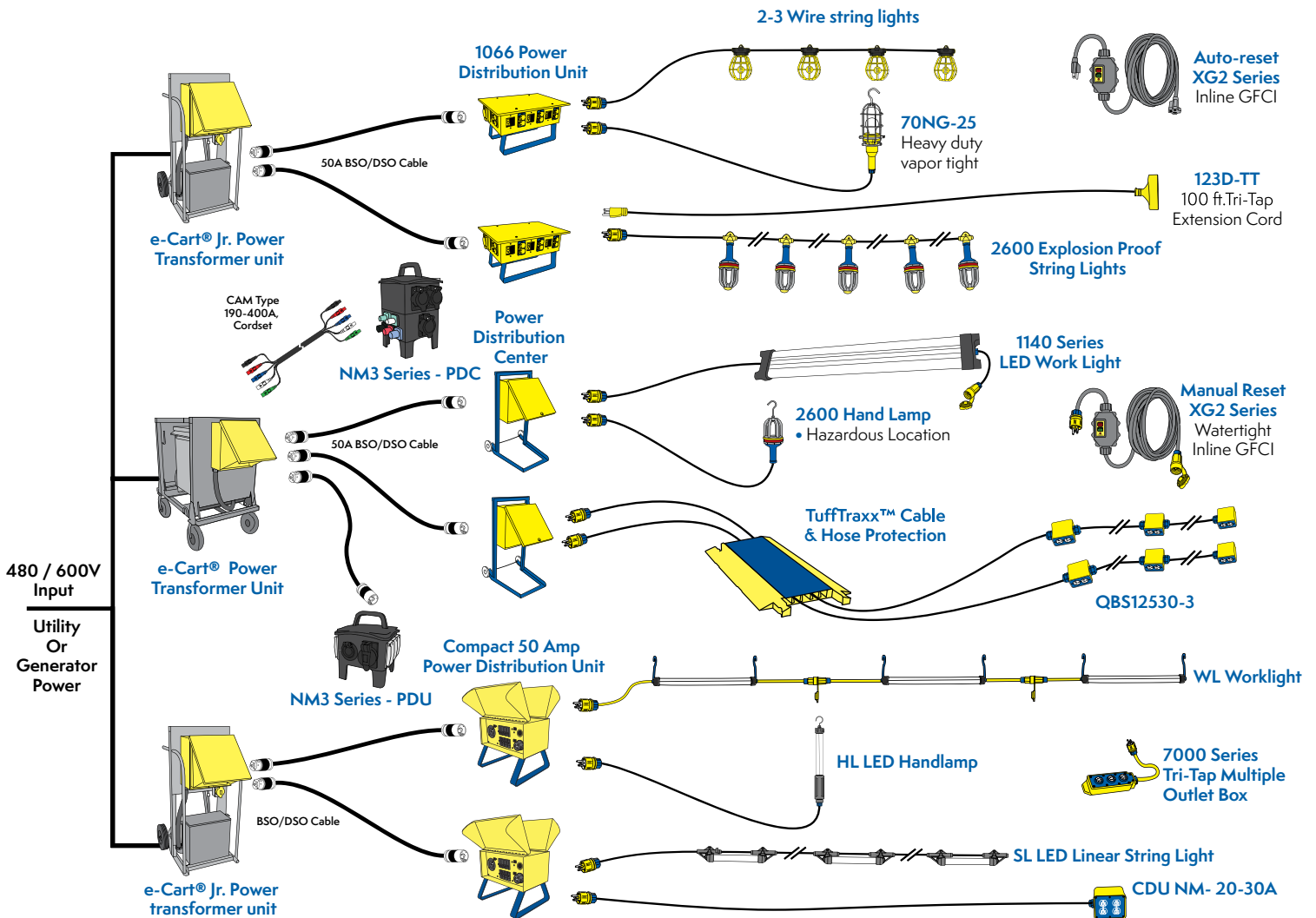

# 2-Wheel Open Frame Design

480, 600 & Dual Primary, 480/600-Volt, 15kVA



## Standard Features:

### Frame:

- Rugged aluminum, steel, or stainless steel frame is designed to protect critical electrical components
- Narrow Design is easily repositioned within narrow spaces on the jobsite
- Welded lifting hooks and available fork tube pockets are designed for easy rigging and repositioning throughout the jobsite

### Primary Connection:

- 480 or 600-Volt Fused Disconnect Standard
- Range of input connections available
- Optional 480/600-Volt dual primary and tap switch available

### Transformer:

- 15 kVA Dry type or Encapsulated, with various primary transformer voltages available
- Standard 3-phase 208Y/120-volt or single phase 120/240
- Various single and 3-phase secondary voltage and configurations available

### Secondary Combo Box Load Center:

- Nema 3R Rated
- Powder Coated Steel or Stainless Steel Standard
- Customizable, 4 Sub-Panel Design allows several standard or customized secondary power options

## Market Applications:

- Maintenance and Construction
- Power & Lighting
- Power Generation
- Ship Building
- Mining
- Food and Beverage
- Aerospace
- Emergency Response
- Temporary Shelter
- Military Applications



## Unique Features:



Robust frame design protects critical electrical components



NEMA 3R Enclosed 4 Sub-Panel Design offers a wide range of receptacle options



Solid rubber wheels mounted at the center line of transformation weight for easy repositioning



Welded lifting eyes designed for easy rigging and repositioning

# 2-Wheel Open Frame Design

15 kVA



## Selection Guide

Part Number	kVA	Primary Configuration	Secondary Voltage	Secondary MLO/MCB	20A	CS6369 50A	L6-30
<b>15kVA, Single Phase 480-Volt Primary</b>							
EJR4115CL10600	15	60A Disc SW w/6' Primary Cable	120/240V	MLO	(6) 5-20 GFCI Duplex Rcpts	0	0
EJR4115CM1061	15	60A Disc SW w/6' Primary Cable	120/240V	MCB	(6) 5-20 GFCI Duplex Rcpts	1	0
EJR4115PL10600	15	60A Disc SW w/6' Primary Cable	120/240V	MLO	(6) 5-20C Pigtails	0	0
<b>15kVA, 3 Phase, 480-Volt Primary</b>							
EJR4315CL3060	15	30A Disc SW w/6' Primary Cable	208Y/120	MLO	(6) 5-20 GFCI Duplex Rcpts	0	0
EJR4315CM3061	15	30A Disc SW w/6' Primary Cable	208Y/120	MCB	(6) 5-20 GFCI Duplex Rcpts	1	0
EJR4315CM30602	15	30A Disc SW w/6' Primary Cable	208Y/120	MCB	(6) 5-20 GFCI Duplex Rcpts	0	2
EJR4315CL31200	15	30A Disc SW w/6' Primary Cable	208Y/120	MLO	(12) 5-20 GFCI Duplex Rcpts	0	0
EJR4315CM3120	15	30A Disc SW w/6' Primary Cable	208Y/120	MCB	(12) 5-20 GFCI Duplex Rcpts	0	0
EJR4315PL30600	15	30A Disc SW w/6' Primary Cable	208Y/120	MLO	(6) 5-20C Pigtails	0	0
EJR4315PL3060L	15	30A Disc SW w/6' Primary Cable	208Y/120	MLO	(6) L5-20C Pigtails	0	0
EJR4315PM3120	15	30A Disc SW w/6' Primary Cable	208Y/120	MCB	(12) 5-20C Pigtails	0	0
EJR4315PM3120L	15	30A Disc SW w/6' Primary Cable	208Y/120	MCB	(12) L5-20C Pigtails	0	0
<b>15kVA, 3 phase, 600-Volt Primary</b>							
EJR6315CM3061	15	30A Disc SW w/6' Primary Cable	208Y/120	MCB	(6) 5-20 GFCI Duplex Rcpts	1	0
EJR6315CM31200	15	30A Disc SW w/6' Primary Cable	208Y/120	MCB	(12) 5-20 GFCI Duplex Rcpts	0	0
<b>15kVA - 3 phase - Dual Primary 480/600-Volt</b>							
EJRDP64315CM3060	15	30A Disc, 480/600V w/6' Primary Cable	208Y/120	MCB	(6) 5-20 GFCI Duplex Rcpts	0	0

Note: cETLus Listed

Dimensions: EJR 4 Frame

Approximate Weight: 325lbs.

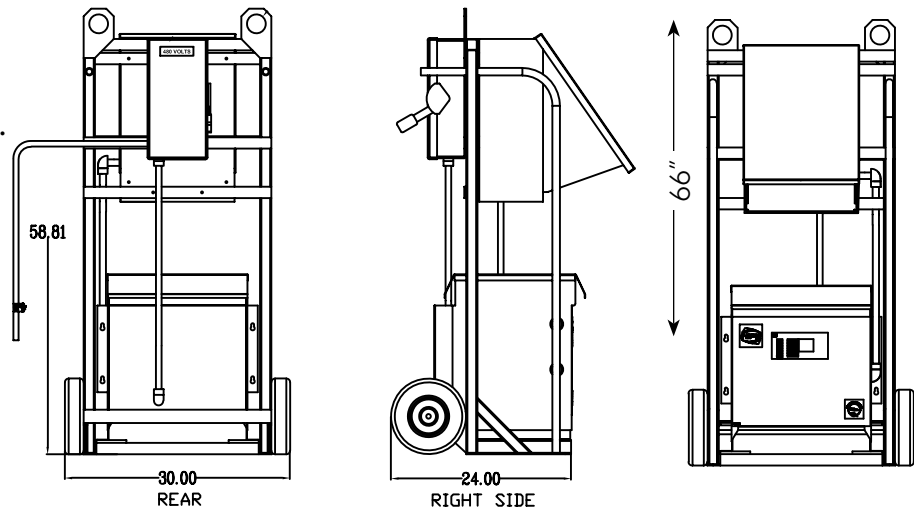

# 2-Wheel Open Frame Design

480, 600 & Dual Primary, 480/600-Volt, 25 - 45kVA



## Standard Features:

### Frame:

- Rugged aluminum, steel, or stainless steel frame is designed to protect critical electrical components
- Narrow Design is easily repositioned within narrow spaces on the jobsite
- Welded lifting hooks and fork tube pockets are designed for easy rigging and repositioning throughout the jobsite

### Primary Connection:

- 480 or 600-Volt Fused Disconnect Standard
- Range of input connections available
- Optional 480/600-Volt dual primary with tap switch

### Transformer:

- 25-45kVA Dry type or Encapsulated, with various primary transformer voltages available
- Standard 3-phase 208Y/120-volt or single phase 120/240
- Various single and 3-phase secondary voltage and configurations available

### Secondary Combo Box Load Center:

- Nema 3R Rated
- Powder Coated Steel or Stainless Steel Standard
- Customizable, 4 Sub-Panel Design allows several standard or customized secondary power options

## Market Applications:

- Maintenance and Construction Power & Lighting
- Power Generation
- Ship Building
- Mining
- Food and Beverage
- Aerospace
- Emergency Response
- Temporary Shelter
- Military Applications



## Unique Features:



Robust frame design protects critical electrical components



NEMA 3R Enclosed 4-Sub-panel box offers a wide range of receptacle solutions



Hard rubber wheels mounted at the center line of transformer weight & fork tubes for easy jobsite repositioning



Welded Lifting Eyes designed for easy rigging and repositioning

# 2-Wheel Open Frame Design 25-45 kVA



Part Number	kVA	Primary Configuration	Secondary Voltage	Secondary MLO/MCB	20A	CS6369 50A	L6-30
<b>25kVA, Single phase, 480-Volt Primary</b>							
EJR24125CM1100	25	100A Disc SW w/6' Primary Cable	120/240V	MCB	(10) 5-20 GFCI Duplex	0	0
<b>30kVA, 3 phase, 480-Volt Primary</b>							
EJR24330CL3061	30	60A Disc SW w/6' Primary Cable	208Y/120	MLO	(6) 5-20 GFCI Duplex	1	0
EJR24330CM3061	30	60A Disc SW w/6' Primary Cable	208Y/120	MCB	(6) 5-20 GFCI Duplex	1	0
EJR24330CM31002	30	60A Disc SW w/6' Primary Cable	208Y/120	MCB	(10) 5-20 GFCI Duplex	0	2
EJR24330CL3120	30	60A Disc SW w/6' Primary Cable	208Y/120	MLO	(12) 5-20 GFCI Duplex	0	0
EJR24330PM3160	30	60A Disc SW w/6' Primary Cable	208Y/120	MCB	(16) 5-20C Pigtails	0	0
<b>30kVA, 3 phase, 480/600-Volt Dual Primary</b>							
EJR2DP64330PM3160	30	60A Disc SW w/6' Primary Cable	208Y/120	MCB	(16) 5-20C Pigtails	0	0
<b>30kVA, 3 phase, 600-Volt Primary</b>							
EJR26330CL3120	30	60A Disc SW w/6' Primary Cable	208Y/120	MLO	(12) 5-20 GFCI Duplex	0	0
<b>37.5kVA, Single phase, 480-Volt Primary</b>							
EJR24137CM1101	37.5	100A Disc SW w/6' Primary Cable	208Y/120	MCB	(10) 5-20 GFCI Duplex	1	0
<b>45kVA, 3 phase, 480-Volt Primary</b>							
EJR24345XXCL3121	45	100A Disc SW w/6' Primary Cable	208Y/120	MLO	(12) 5-20 GFCI Duplex	1	0
<b>45kVA, 3 phase, 600-Volt Primary</b>							
EJR26345CL3121	45	60A Disc SW w/6' Primary Cable	208Y/120	MLO	(12) 5-20 GFCI Duplex	1	0

Notes: 1. cETLus Listing  
2. Available for 25-45kVA, Single phase or 3 phase

**Dimensions:** EJ2 Frame

**Approximate Weight:** 400lbs.

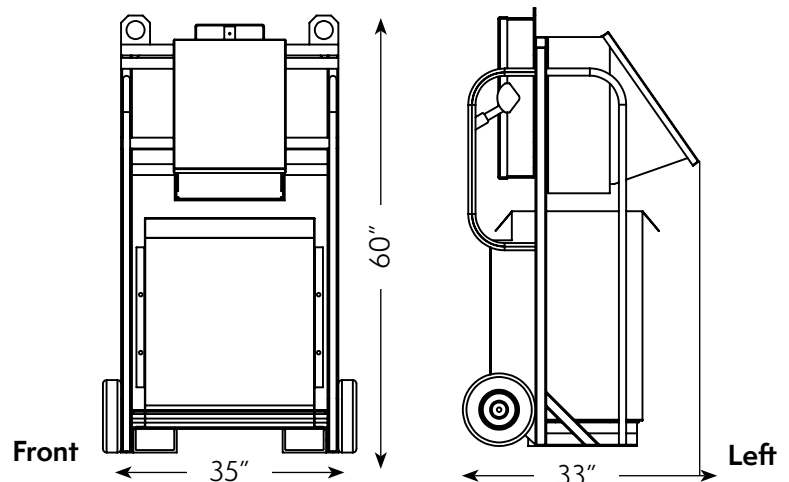



# 2-Wheel Cage Frame Design

480, 600 & Dual Primary, 480/600-Volt, 25-45kVA



## Standard Features:

### Frame:

- Robustly designed aluminum, steel, or stainless steel frame protects critical electrical components
- Available "Roof Design" for environmental protection
- Narrow Design is easily repositioned within narrow spaces on the jobsite
- Welded lifting hooks and fork tube pockets are designed for easy rigging and repositioning throughout the jobsite

### Primary Connection:

- 480 or 600V Fused Disconnect Standard
- Range of input connections available
- Optional 480/600V dual primary with tap switch

### Transformer:

- 25-45kVA Dry type or Encapsulated, with various primary transformer voltages available
- Standard 3-phase 208Y/120-volt or single phase 120/240
- Various single and 3-phase secondary voltage and configurations available

### Secondary Combo Box Load Center:

- Nema 3R Rated
- Powder Coated Steel or Stainless Steel Standard
- Customizable, 4 Sub-Panel Design allows several standard or customized secondary power options

\*Available as a custom build - see page 25 to design your own

## Market Applications:

- Refining, Oil & Gas
- Mining
- Maintenance, Construction Power & Lighting
- Food and Beverage
- Aerospace
- Power Generation
- Emergency Response
- Ship Building
- Temporary Shelter
- Military Applications



## Unique Features:



480/600-Volt dual primary tap switch. Exoskeleton cage frame protects critical electrical components



Powder Coated or stainless steel combo box with 4 sub-panels offer a wide range of secondary receptacle options



Hard rubber wheels mounted at the center line of transformer weight & fork tubes for easy jobsite repositioning



Welded Lifting Eyes designed for easy rigging and repositioning

# 2-Wheel Steel Caged Frame Design

480, 600 & Dual Primary, 480/600-Volt, 25-45kVA



EJR-4-4330-PM3161

## Standard Features:

### Frame:

- Robustly designed steel, aluminum or stainless steel frame protects critical electrical components
- Roof Design for environmental protection
- Narrow Design is easily repositioned within narrow spaces on the jobsite
- Lifting eyes and fork tube pockets are designed for easy rigging and repositioning throughout the jobsite

### Primary Connection:

- 480 or 600-Volt Fused Disconnect Standard
- Range of input connections available
- Optional 480/600V dual primary and tap switch available

### Transformer:

- 15-45kVA Dry type or Encapsulated, with various primary transformer voltages available
- Standard 3-phase 208Y/120-volt or single phase 120/240
- Various single and 3-phase secondary voltage and configurations available

### Secondary Combo Box Load Center:

- Nema 3R Rated
- Powder Coated Steel or Stainless Steel Standard
- Customizable, 4 Sub-Panel Design allows several standard or customized secondary power options

## Market Applications:

- Refining, Oil & Gas
- Mining
- Maintenance, Construction Power & Lighting
- Food and Beverage
- Aerospace
- Power Generation
- Emergency Response
- Ship Building
- Temporary Shelter
- Military Applications



## Unique Features:



Steel Protective exo-skeleton cage frame protects critical electrical components



Powder Coated or stainless steel Combo Box with secondary watertight pigtails offers watertight connections



Hard rubber wheels mounted at the center line of transformer weight & fork tubes for easy jobsite repositioning



Bolted Eyes offer secure lifting protection for jobsite repositioning

# 2-Wheel Steel Cage Frame Design

25-45 kVA



## Selection Guide

Part Number	kVA	Phase	Primary Configuration	Secondary Voltage	Secondary MLO/MCB	20A Receptacles	CS6369 50A Rcpt	L6-30 Rcpt
<b>25kVA 2 wheel - Single phase - 480-Volt Primary</b>								
EJR-4-4325-CM3061	25	1	100A Disc SW w/6' Primary Cable	240/120	MCB	(6) 5-20 GFCI Duplex	1	0
<b>30kVA 2 wheel - 3 phase - 480-Volt Primary</b>								
EJR-4-4330-CM3121	30	3	60A Disc SW w/6' Primary Cable	208Y/120	MCB	(12) 5-20 GFCI Duplex	1	0
EJR-4-4330-PM3160	30	3	60A Disc SW w/6' Primary Cable	208Y/120	MCB	(16) 5-20C Pigtails	0	0
<b>30kVA 2 wheel - 3 phase - 600-Volt Primary</b>								
EJR-4-6330-CM3061	30	3	60A Disc SW w/6' Primary Cable	208Y/120	MCB	(6) 5-20 GFCI Duplex	1	0
<b>30kVA 2 wheel - 3 phase -480/600-Volt Dual Primary</b>								
EJR-4-DP64330-CM31002	30	3	60A Disc SW w/6' Primary Cable	208Y/120	MCB	(10) 5-20 GFCI Duplex	0	2
<b>45kVA 2 wheel - 3 phase - 480-Volt Primary</b>								
EJR-4-4345-CM3034	45	3	100A Disc SW w/6' Primary Cable	208Y/120	MCB	(3) 5-20 GFCI Duplex	4	0

Notes: 1. Available for 15-50 kVA, Single phase or 3 phase  
2. See page 26 for customizing options.

Dimensions: EJ4 Frame

Approximate Weight: 575lbs.

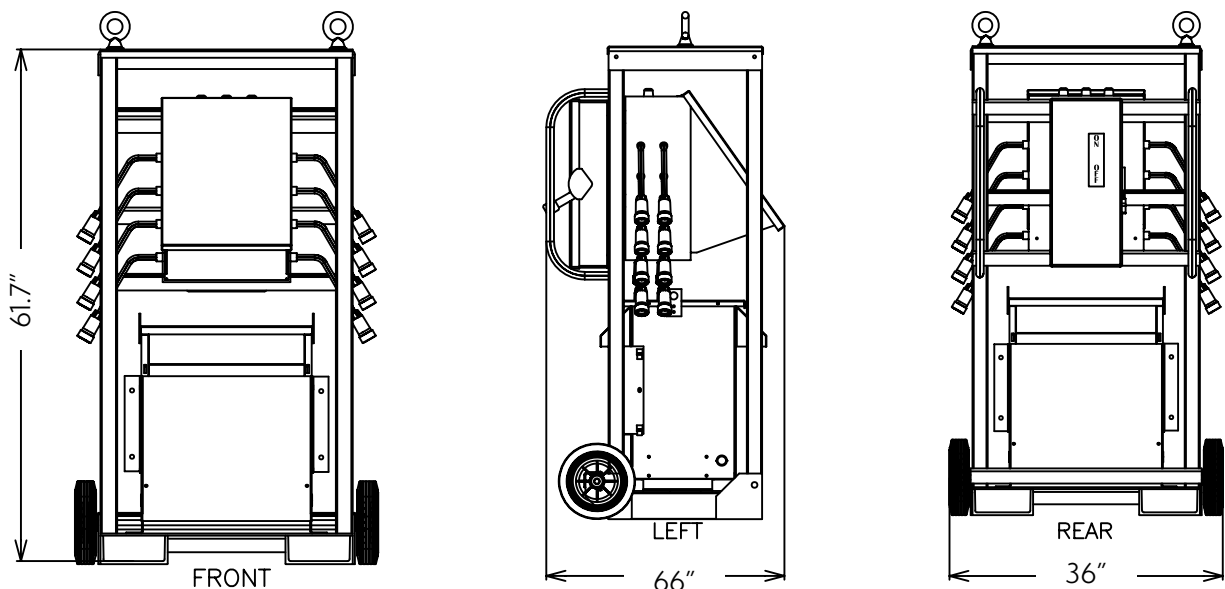

# 4-Wheel Open Frame e-Cart® Design

480-600-Volt, Single and 3-Phase, 25-112.5kVA



## Standard Features:

### Frame Design:

- Rugged aluminum, steel, or stainless steel frame is designed to protect critical electrical components
- Lifting Eyes and Fork Tubes for easily jobsite repositioning
- 4-wheel design for easy maneuverability
- Optional wheel designs available

### Primary Electrical Configurations:

- Dual Primary - 480/600V Primary Available
- Available Primary Fused Disconnect or Primary Panel with Main Circuit Breaker Protection
- Various Primary Connection Means Available (cord, IEC Pin & Sleeve, CAM Type Connections.)

### Transformer:

- 25-112.5kVA Dry type or Encapsulated, with various primary transformer voltages available
- Standard 3-phase 208Y/120-volt or single phase 120/240
- Various single and 3-phase secondary voltage and configurations available

### Secondary Combo Box Load Center:

- Nema 3R Rated
- Powder Coated Steel or Stainless Steel available
- Customizable, 4 Sub-Panel Design allows several standard or customized secondary power options

## Market Applications:

- Refining, Oil & Gas
- Mining
- Maintenance, Construction Power & Lighting
- Food and Beverage
- Aerospace
- Power Generation
- Emergency Response
- Ship Building
- Temporary Shelter
- Military Applications



## Unique Features:



Open 4 wheel frame design allows easy access to electrical components



Combo Box can be used for service entrance and primary connections as well as 4-sub panels of customized secondary power receptacles.



Non-marking wheels with iron hub, mounted at the corners for easy maneuverability



Welded Lifting Eyes & fork tubes designed for easy rigging and jobsite repositioning. Optional top lifting eyes

# 4-Wheel Open Frame e-Cart® Design 25-112.5kVA



## Selection Guide

Part Number	Frame	kVA	Primary	Secondary Voltage	Secondary MLO/MCB	20A GFCI DPLX	CS6369 50A	L6-30	cETLus Listing
<b>30kVA, 3 phase, 480-Volt Primary</b>									
EC2-A-4330-CL31002	A	30	60A Disc SW w/6' Primary Cable	208Y/120	MLO	10	0	2	Yes
EC2-A-4330-CM3122	A	30	60A Disc SW w/6' Primary Cable	208Y/120	MCB	12	2	0	Yes
<b>30 kVA, 3 phase - 600-Volt Primary</b>									
EC2-A-6330-CM3122	A	30	60A Disc SW w/6' Primary Cable	208Y/120	MCB	12	2	0	Yes
<b>45 kVA, 3 phase - 480-Volt Primary</b>									
EC2-A-4345-CM3034	A	45	100A Disc SW w/6' Primary Cable	208Y/120	MCB	3	4	0	Yes
<b>45 kVA, 3 phase - 480-Volt Primary - with Primary &amp; Secondary Panelboards</b>									
EC2-B-4345-2PANEL42CKT	B	45	480/277 MCB 42ckt Panelboard, (1) 60A 3P CB for Transformer	208Y/120	MCB	208Y/120 125A MCB 42ckt Panelboard, w/o breakers			No
<b>45 kVA, - 3 phase - 600-Volt Primary</b>									
EC2-A-6345-CM3034	A	45	60A Disc SW w/6' Primary Cable	208Y/120	MCB	3	4	0	Yes
<b>75 kVA, 3 phase - 480-Volt Primary</b>									
EC2-B-4375-CM3036	B	75	200A Disc SW w/6' Primary Cable	208Y/120	MCB	3	6	0	Yes
<b>75 kVA, 3 phase - 480-Volt Primary - with Primary &amp; Secondary Panelboards</b>									
EC2-B-4375-2PANEL42CKT	B	75	480/277 MCB 42ckt Panelboard, (1) 100A 3P CB for Transformer	208Y/120	MCB	208Y/120 200A MCB 42ckt Panelboard, w/o breakers			No
<b>75 kVA, 3 phase - 600-Volt Primary</b>									
EC2-B-6375-CM3036	B	75	100A Disc SW w/6' Primary Cable	208Y/120	MCB	3	6	0	Yes

**Note:** See page 26 for customizing options.

# 4-Wheel

## Open Frame Design

25-112.5kVA

EC2 Frame A - 25-45kVA

Approximate Weight: 600-750lbs.

Primary Side

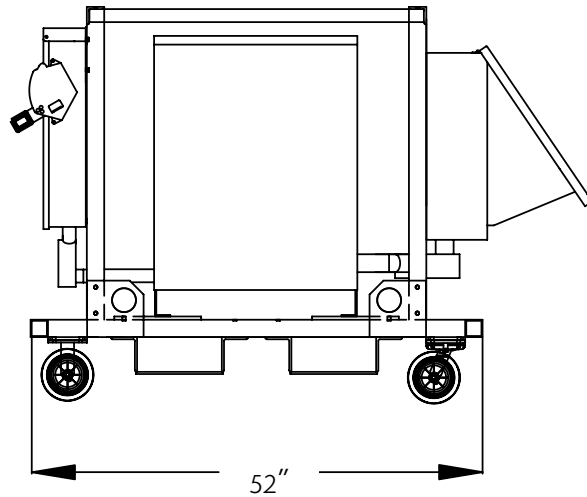
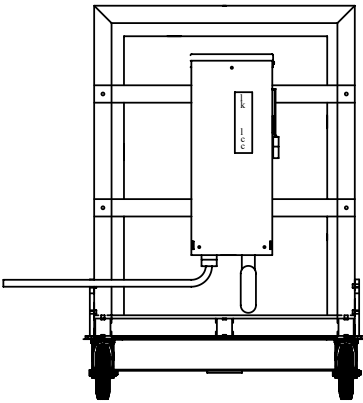

Secondary Side

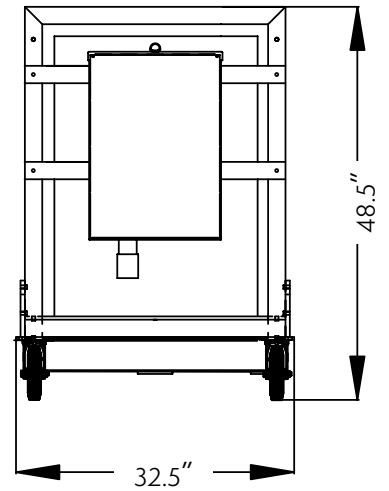

EC2 B Frame - Tall 75-112.5kVA

Approximate Weight: 800-900lbs.

Primary Side

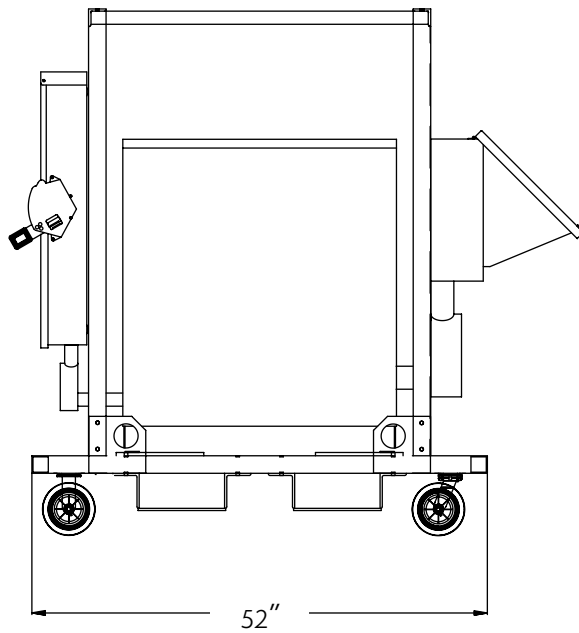
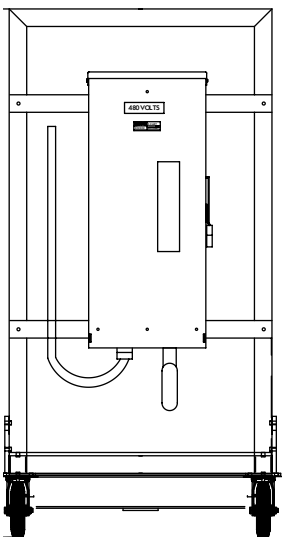

Secondary Side

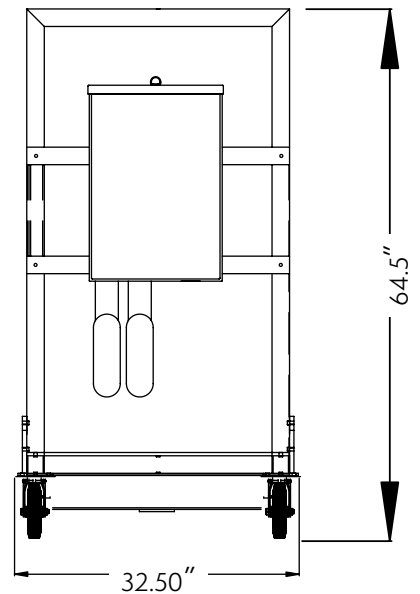

# 4-Wheel Steel Cage Frame e-Cart® Design

480-600-Volt, 30-75kVA



## Standard Features:

### Frame Design:

- Rugged steel, aluminum or stainless steel cage design protects critical electrical components
- Lifting Eyes and Fork Tubes for easy jobsite repositioning
- 4-wheel design for easy maneuverability
- Optional wheel designs available

### Primary Electrical Configurations:

- Available in 480, 600, and Dual Primary, Single or 3-Phase
- Available Primary Fused Disconnect or Primary Panel with Main Circuit Breaker Protection
- Various Primary Connections Available, (cord, IEC Pin & Sleeve, CAM Type Connections.)

### Transformer:

- 45-75kVA Dry type or Encapsulated, with various primary transformer voltages available
- Standard 3-phase 208Y/120 or single phase 120/240
- Various single and 3-phase secondary voltage and configurations available

### Secondary Combo Box Load Center or Secondary Panel:

- Nema 3R Rated
- Powder Coated Stainless Steel or Aluminum
- Customizable secondary panel or 4 Sub-Panel Design allow several standard or customized secondary power options

## Market Applications:

- Maintenance and Construction Power & Lighting
- Power Generation
- Ship Building
- Mining
- Food and Beverage
- Aerospace
- Emergency Response
- Temporary Shelter
- Entertainment
- Military Applications



## Unique Features:



Fully compliant Powder Coated steel frame securely protects critical electrical components



4-Sub panel Combo Box is available in Powder Coated steel or stainless steel



Various wheel options are available and mounted at the corners to easily reposition carts on the job site

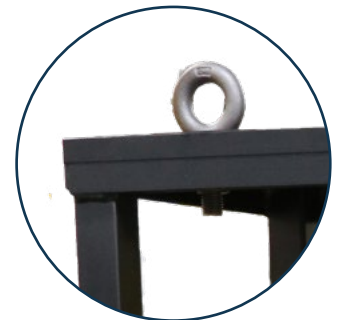

Welded Lifting Eyes designed for easy rigging and repositioning

# 4-Wheel Steel Cage Frame Design

30-75 kVA



## Selection Guide

Part Number	Phase	kVA	Primary Voltage	Secondary Voltage	Secondary MLO/MCB	20A GFCI DPLX	CS6369 50A	L6-30	cETLus Listing
<b>30kVA 4 wheel - 3 phase - 480V Primary</b>									
EC2-D-4330-CM3122	3	30	60A Disc SW w/6' Primary cable	208Y/120	MCB	12	2	0	Yes
<b>45kVA 4 wheel - 3 phase - 480V Primary</b>									
EC2-D-4345-CM3034	3	45	100A Disc SW w/6' Primary Cable	208Y/120	MCB	3	4	0	Yes
<b>45kVA 4 wheel - 3 phase - 600V Primary</b>									
EC2-D-6345-CM3034	3	45	60A Disc SW w/6' Primary Cable	208Y/120	MCB	3	4	0	Yes
<b>75kVA 4 wheel - 3 phase - 480V Primary</b>									
EC2-D-4375-CM3036	3	75	200A Disc SW w/6' Primary Cable	208Y/120	MCB	3	6	0	Yes
<b>75kVA 4 wheel - 3 phase - 600V Primary</b>									
EC2-D-6375-CM3036	3	75	100A Disc SW w/6' Primary Cable	208Y/120	MCB	3	6	0	Yes

- Notes:** 1. Available for 25-112.5kVA, Single or 3-phase  
 2. Available with Primary and Secondary Panelboards  
 3. See page 25 for customizing options.

## Dimensions: EC2-D Frame

**Approximate Weight: 1200-1400lbs.**

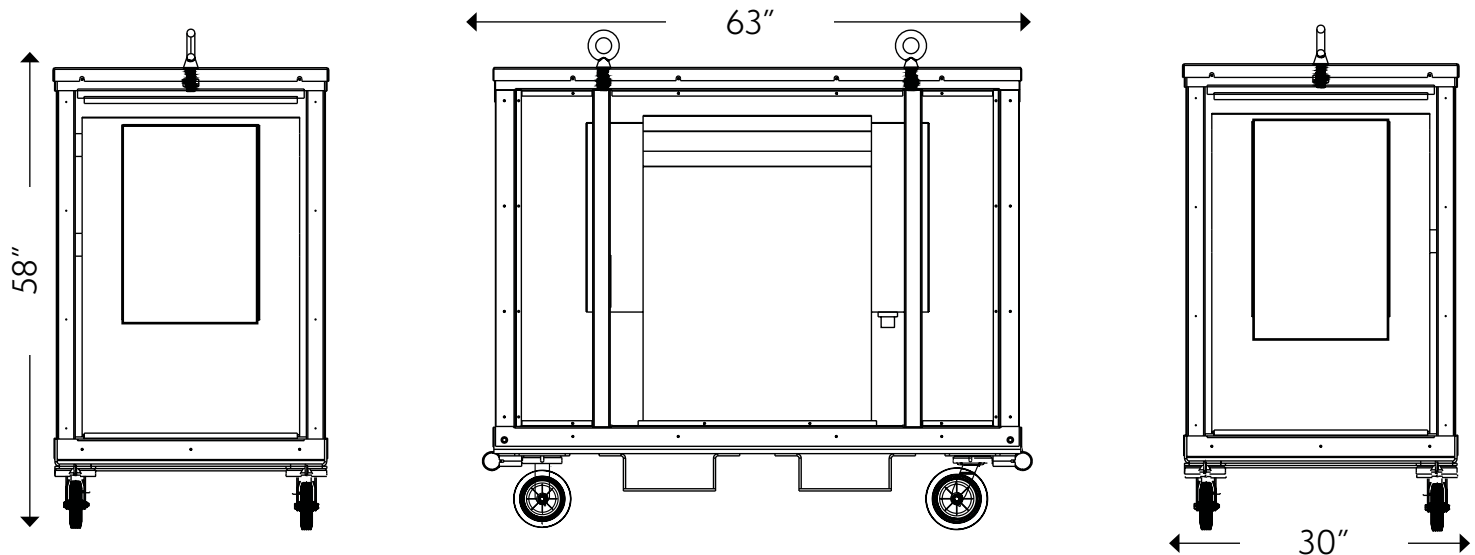



# 4-Wheel Enclosed Cage Frame Design

480-600-Volt, 45-75kVA



## Standard Features:

### Frame Design:

- Rugged steel, aluminum or stainless steel cage design, with roof and sides protects critical electrical components
- Lifting Eyes and Fork Tubes for easy jobsite repositioning
- 4-wheel design for easy maneuverability
- Optional wheel designs available

### Primary Electrical Configurations:

- Available in 480, 600, and Dual Primary, Single or 3-Phase
- Available Primary Fused Disconnect or Primary Panel with Main Circuit Breaker Protection
- Various Primary Connection Means Available (cord, IEC Pin & Sleeve, CAM Type Connections.)

### Transformer:

- 45-75kVA Dry type or Encapsulated, with various primary transformer voltages available
- Standard 3-phase 208Y/120 or single phase 120/240
- Various single and 3-phase secondary voltage and configurations available

### Secondary Combo Box Load Center or Secondary Panel:

- Nema 3R Rated
- Powder Coated Stainless Steel or Aluminum
- Customizable secondary panel or 4 Sub-Panel Design allow several standard or customized secondary power options

## Market Applications:

- Maintenance and Construction Power & Lighting
- Power Generation
- Ship Building
- Mining
- Food and Beverage
- Aerospace
- Emergency Response
- Temporary Shelter
- Military Applications



## Unique Features:



Enclosed frame promotes clean look without tampering. Available for company or project personalization



Primary or secondary enclosures available in Powder Coated or stainless steel finish



Rugged pivot lock wheels will break, makes jobsite repositioning safe and easy



Bolted Lifting Eyes designed for easy rigging and repositioning

# 4-Wheel Enclosed Frame Design

75 kVA



Part Number	Phase	kVA	Primary	Secondary Voltage	Secondary ML/MCB	20A GFCI DPLX	CS6369 50A	L6-30	cETLus Listing	Approx. Weight
<b>75kVA 4 wheel - 3 phase - Enclosed - 480V Primary</b>										
<b>EC2-D-4375-CM3036-ENC</b>	3	75	200A Fused Disc SW w/6' cable	208Y/120	MCB	3	6	0	Yes	1200

**Note:** Other kVA Transformer sizes, primary and or secondary panel configurations available.

**Dimensions:** EC2-D Frame

**Approximate Weight:** 1400lbs.

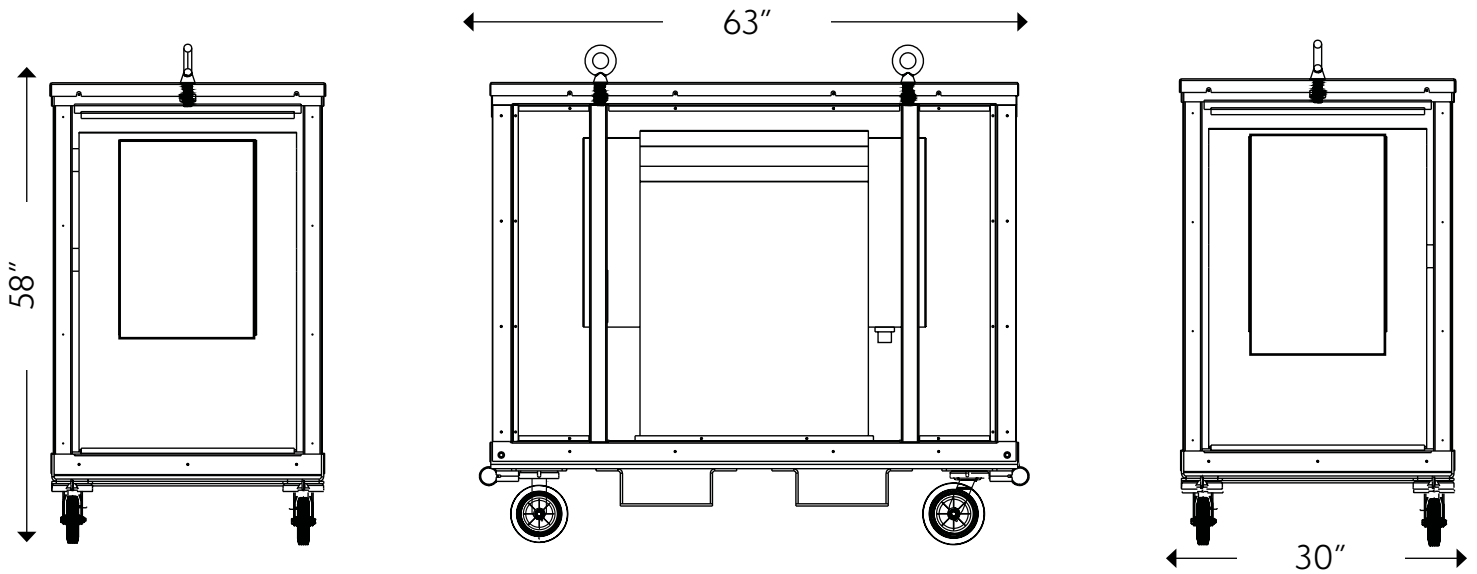

# Part Number Nomenclature:

## 2-Wheel Carts

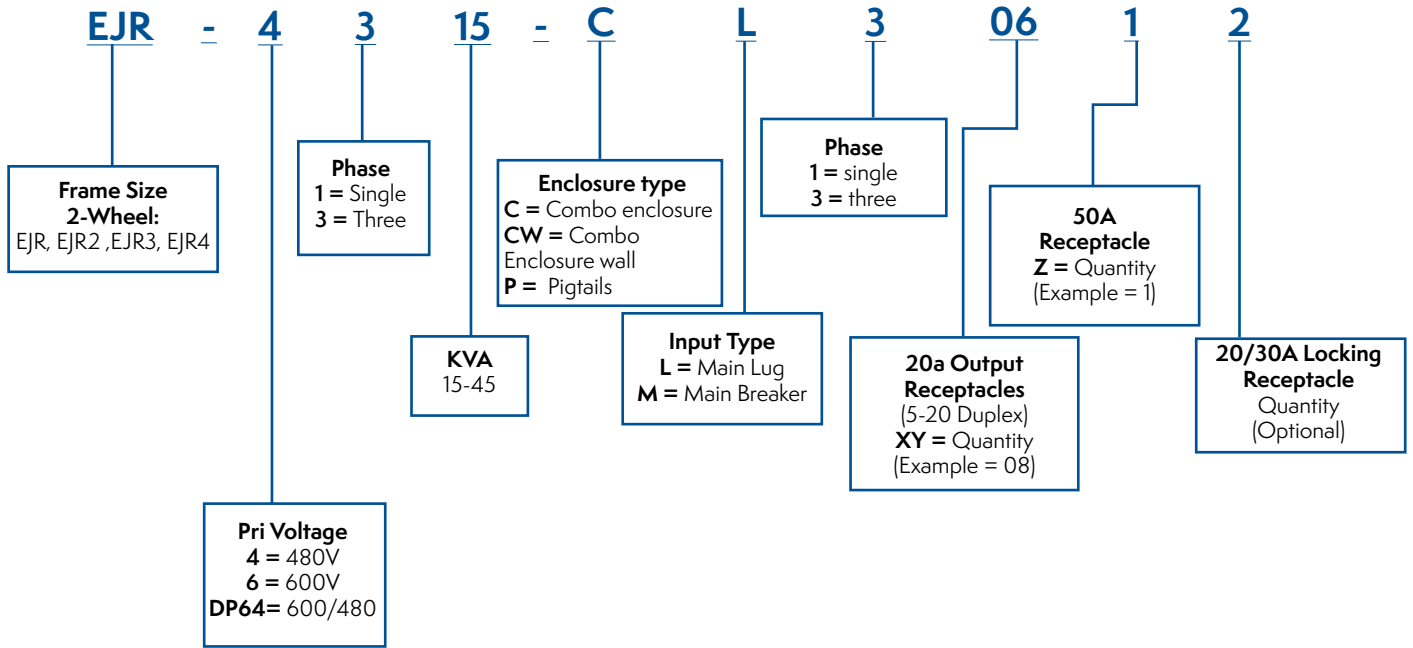

## 4-Wheel Carts

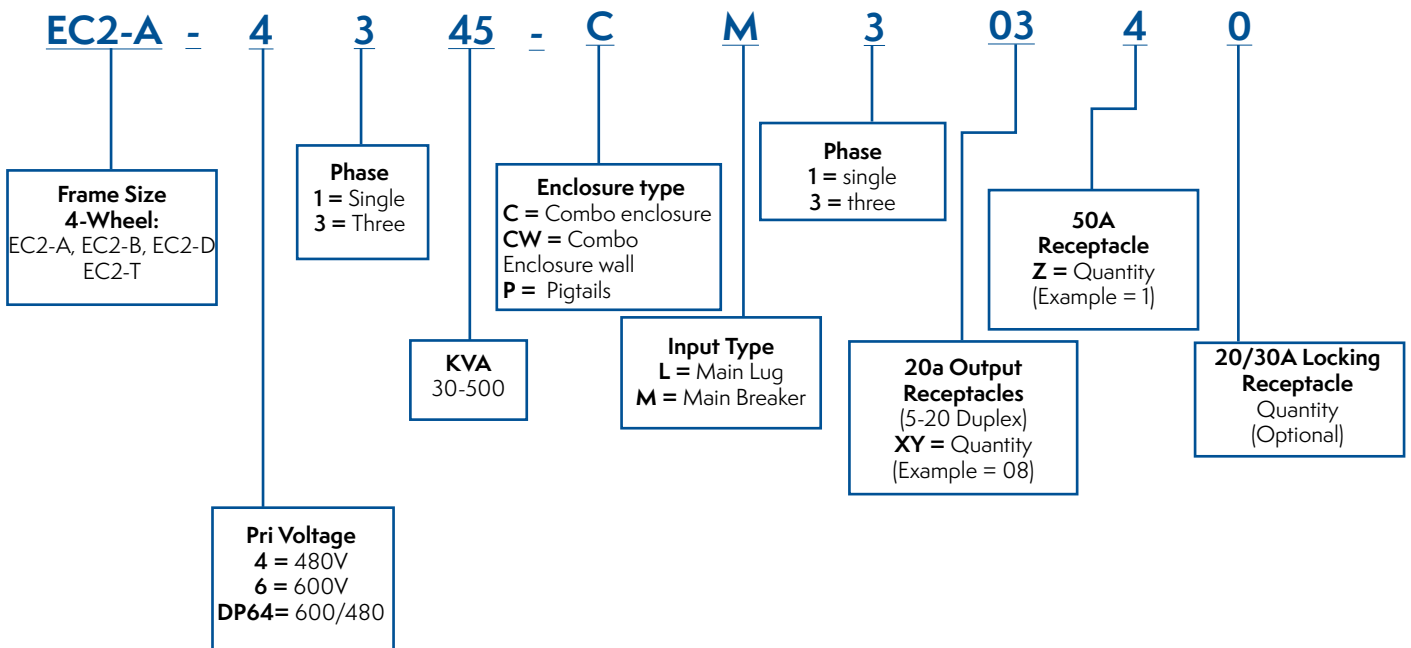

# T-Frame 2-Sided e-Cart® Design



## Standard Features:

- NEMA 3R rated
- Heavy Duty Aluminum or optional Powder Coated steel frame
- NEMA 3R fused primary disconnect, sized per transformer
- Easy to move, narrow frame fits through a standard 36" doorway
- Other NEMA configuration receptacles available
- cCSAus factory certification available
- Removable 8", 1800lb cap swivel locking casters, and 2 high stacking capability
- Product customization are available upon request

## Market Applications:

- Refineries
- Petrochemical Plants
- Power Plants
- Maintenance and Construction Power & Lighting
- Power Generation
- Ship Building
- Mining
- Food and Beverage
- Aerospace
- Emergency Response
- Temporary Shelter
- Military Applications



## Unique Features:



Narrow frame design allows for transportation through door frames narrow spaces



Innovative T-Frame design allows multiple electrical components mounted to either side



Low Profile castor type wheels designed to support easy cart repositioning



Adjustable lifting eyes designed for easy rigging and repositioning

# 4-Wheel T-Frame Design

112.5 kVA



Part Number	Phase	kVA	Primary	Secondary Voltage	Secondary ML/MCB	cETLus Listing	Approx Weight
EC2-T-43112-SECPANEL	3	112.5	480	208Y/120	(2) 150A panelboards, each with 150A 3P MCB	N/A	2000

Dimensions: T-Frame Standard

Approximate Weight: 2000lbs.

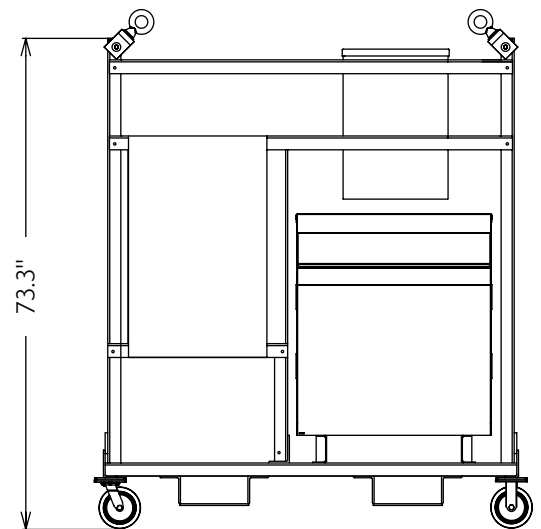
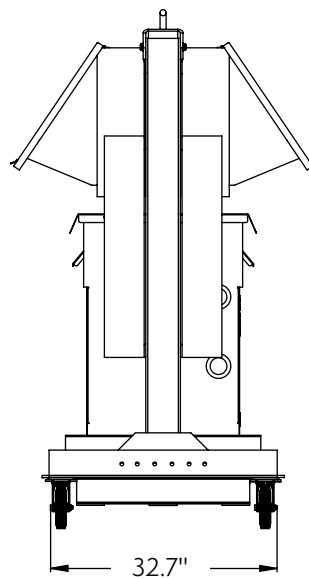
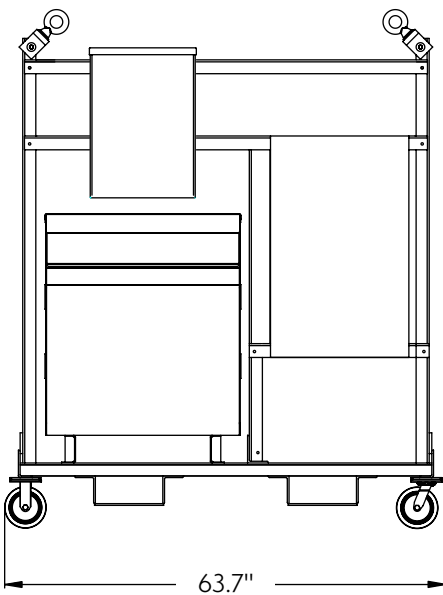

# High kVA Steel Cage Frame Stackable Design

Dual Primary 480/600-Volt, 75-500kVA

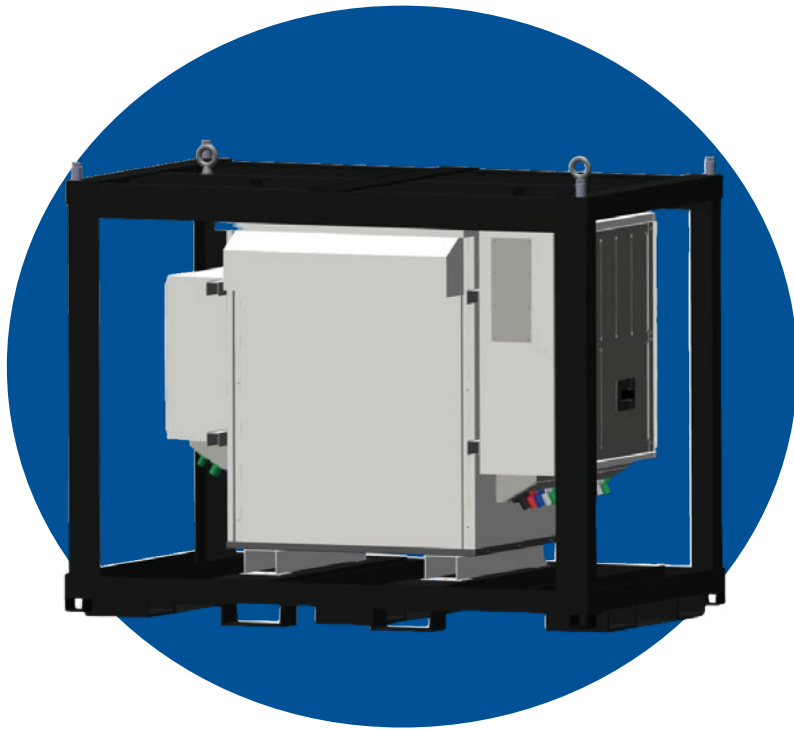

## Standard Features:

- Dual Primary voltage input capability, 480/600-Volt
- 75 to 500 KVA
- CAM Type primary and secondary connections
- Primary and secondary main breakers

### Frame Design:

- Rugged steel or aluminum cage frame design securely protects critical electrical components
- Lifting Eyes and Fork Tubes for easily jobsite repositioning

### Primary Electrical Configurations:

- Available in 480, 600, and Dual Primary, Single or 3-Phase
- Available Primary Fused Disconnect or Primary Panel with Main Circuit Breaker Protection
- Various Primary Connection Means Available (Hard wire, IEC Pin & Sleeve, CAM Type Connections.)

## Market Applications:

- Maintenance and Construction Power & Lighting
- Power Generation
- Ship Building
- Mining
- Food and Beverage
- Aerospace
- Emergency Response
- Temporary Shelter
- Military Applications



## Selection Guide

Part Number	kVA	Phase	Primary CB	Secondary Voltage	Secondary MCB	Secondary Output
<b>Dual Primary 480/600-Volt</b>						
EC3-G-64375-1	75	3	100A 3P Breaker	208Y/120	200A 3P MCB	1 set of 5 Camlock
EC3-H-643150-1	150	3	200A 3P Breaker	208Y/120	400A 3P MCB	1 set of 5 Camlock
EC3-H-643225-1	225	3	300A 3P Breaker	208Y/120	600A 3P MCB	2 sets of 5 Camlock
EC3-H-643300-1	300	3	400A 3P Breaker	208Y/120	800A 3P MCB	2 sets of 5 Camlock
EC3-J-643500-1	500	3	600A 3P Breaker	208Y/120	(1) 800A 3P, (1) 600A 3P	4 sets of 5 Camlock

# Entertainment Steel Cage Frame Stackable Design

Bi-Directional, Dual Primary 480/600-Volt, 45-300kVA

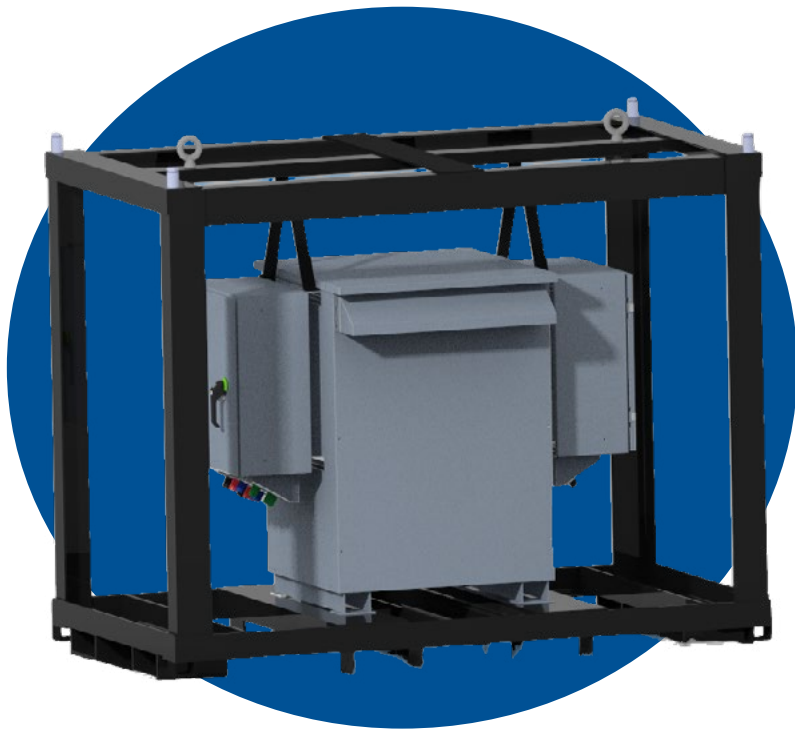

## Standard Features:

- Unique ability to operate bi-directional, to step up or step down voltages
- 45 to 300kVA
- Camlock input and output connections
- Primary and secondary main breakers

### Frame Design:

- Rugged steel cage Powder Coated frame design securely protects critical electrical components
- Lifting Eyes and Fork Tubes for easily jobsite repositioning
- Stackable frame design to reduce storage space

## Primary Market Applications:

- Entertainment & Convention Applications
- Industrial & Construction Applications



## Selection Guide

Part Number	kVA	Phase	Primary CB	Secondary Voltage	Secondary MCB	Secondary Camlock	20A GFCI DPLX	CS6369 50A	L21-20
<b>Dual Primary 480/600-Volt</b>									
EC4-K-4345-1	45	3	60A 3P Breaker	208Y/120	125A 3P MCB	1 set of 5 camlock input 1 set of 5 camlock output	6	2	6
EC4-L-4375-1	75	3	100A 3P Breaker	208Y/120	200A 3P MCB	1 set of 5 camlock input 1 set of 5 camlock output	6	2	6
EC4-L-43150-1	150	3	200A 3P Breaker	208Y/120	400A 3P MCB	1 set of 5 camlock input 3 sets of 5 camlock output	6	2	6
EC4-M-43300-1	300	3	400A 3P Breaker	208Y/120	(2) 400A 3P (1) 225A 3P Adj. (1) 100A 3P Adj.	2 sets of 5 camlock input 4 sets of 5 camlock output	6	2	6

# Hazardous Location Steel Cage Frame Stackable Design



## Standard Features:

- Class 1, Div 2, Groups C and D Rated
- NEMA 3R rated
- Heavy Duty, Powder Coated steel frame
- NEMA 3R fused primary disconnect, sized per transformer
- Other NEMA configuration receptacles available
- cCSAus factory certification available
- Removable 8", 1800lb cap swivel locking casters, and 2 high stacking capability
- Product customization are available upon request

## Market Applications:

- Refineries
- Petrochemical Plants
- Power Plants



## Unique Features:



Stackable, heavy duty, Powder Coated steel frame



Available Secondary main breaker protects branch breakers



Removable wheels to allow stacking  
*(Optional caster wheels with brakes shown)*



Individual 20 Amp Hazardous Location Receptacles



# 4-Wheel Steel Frame Design

45 kVA



## Selection Guide

Part Number	Frame Style	Primary Voltage	kVA	Phase	Primary	Secondary Voltage	Secondary ML/MCB	20A Single
EC2-F-4345-XPM3180	F	480V	45	3	60A 3P Breaker	208Y/120	100A 3P Breaker	18

**Note:** Other kVA Transformer sizes, primary and or secondary panel configurations available.

## Dimensions- EC2-F Frame

Approximate Weight: 1800lbs.

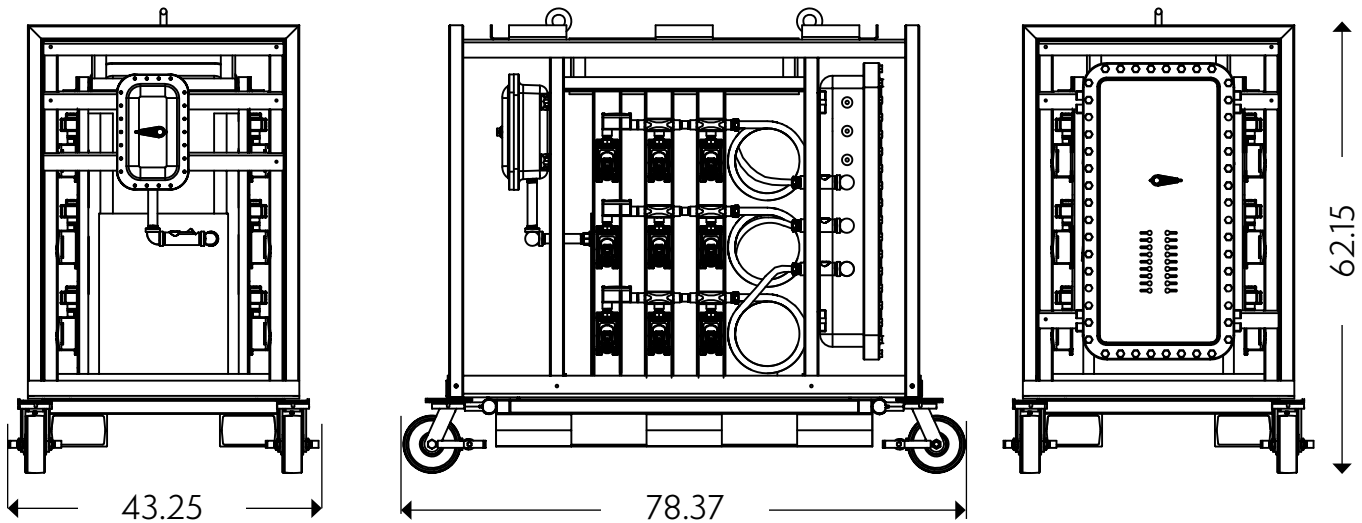

# Design Your Own E-Cart™



Use the fillable spaces below to customize your own e-Cart® by typing or writing into the fields. Once complete, please forward to your Ericson Channel & Applications Team at [sales@ericson.com](mailto:sales@ericson.com).

1. Job name: \_\_\_\_\_

2. Date Quotation is Due: \_\_\_\_\_

3. Cart Quantity: \_\_\_\_\_

4. When will the cart(s) be needed On-Site: \_\_\_\_\_

## 5. Service Area Environment:

Outdoor Rated (NEMA 3R)

Classified Area (C1 or C2, D2)

Severe Service (NEMA 4/4X)

6. Cart Frame Style: \_\_\_\_\_

*(Choose from styles illustrated below.)*

## Two Wheel Frame Styles

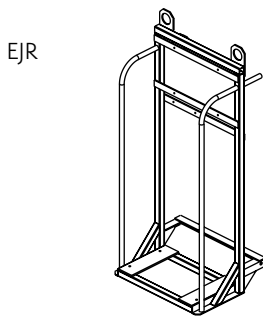

**Two Wheel Open Frame**  
15kVA - Aluminium Standard

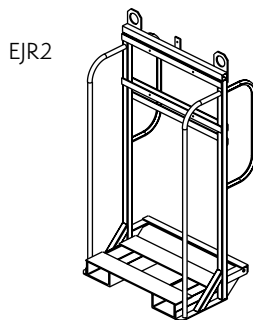

**Two Wheel Open Frame**  
25-45kVA - Aluminium Standard

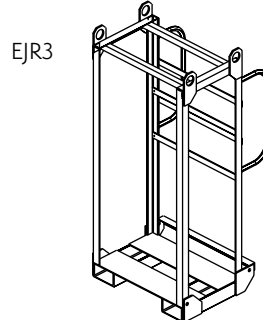

**Two Wheel Cage Frame**  
15-45kVA - Aluminium Standard

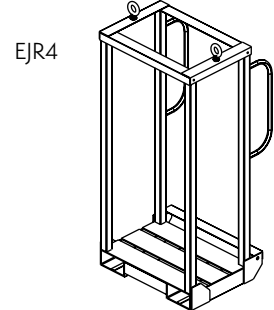

**Two Wheel Cage Frame**  
15-45kVA - Steel Standard

## Four Wheel Frame Styles

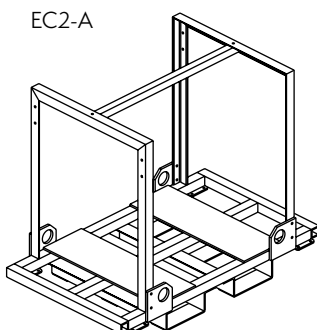

**Four Wheel Open Frame**  
25-45kVA - Aluminium Standard

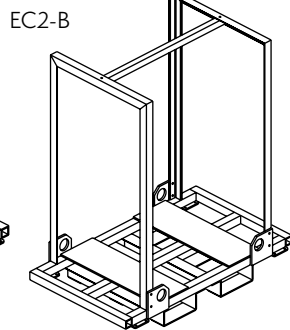

**Four Wheel Open Frame - Tall**  
45-112.5kVA - Aluminium Standard

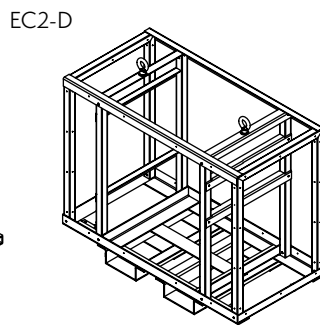

**Four Wheel, Cage**  
25-112.5kVA - Steel Standard

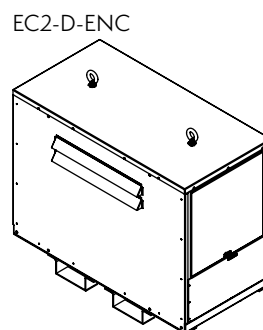

**Enclosed Frame**  
25-112.5kVA - Steel Standard

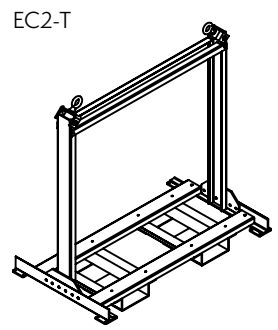

**Custom T-Frame**  
15-112.5kVA - Aluminium Standard

**6a. Preferred Style of Wheels**

Choose one style for all corners.



S2W



S4W



L4W



4CS

**7. What is your primary input power?**

480V 3 Phase 3P4W

600V 3 Phase 3P4W

Phase Indicating Lights

480V/277V 3 Phase 4P5W

600V/347V 3 Phase 4P5W

Primary or Secondary Metering

Dual Primary - 480/600-Volt - 3-Phase with tap switch

Other: (please specify)

**8. Specify your preferred primary input style:**

Hardwired Cable, Blunt End

CamLock Male Inlet Receptacles, 400 AMP Series 16

Hardwired Cable with CAM Type Plugs

Hardwired Cable with Plug (Specify Type, IEC or other)

**9. Specify cable type and length:**

## Primary Input Cordset Design Form

Use the table and spaces below to customize your own Input Cordset for your custom PTU by typing or writing into the fields. Once complete, please forward to your Ericson Channel & Applications Team at sales@ericson.com.

Amp	Poles/Wires	Volts	Cable AWG/# of Conductors	Cable Jacket	Primary Options	Primary Length
30 60 100 200 400	4P/4W 4P/5W	480 600	10/4,5 8/4,5 6/4,5 4/4,5 2/4,5 2/0-4,5 4/0-4,5	SOW Type-W Type G-GGC Other (specify) Color (specify)	Blunt Remove Cable Jacket (Length) Conductor Length(s) Crimp Terminals (specify) IEC309-2 (30-100-Amp) CAM Type, 400-Amp Other (specify)	Specify

10. Do you require a primary enclosure? **Yes:** **No:** *If yes, please complete number 11 and 12 below.*

11. Environmental rating of primary enclosure?

Powder Coated Steel

Stainless Steel

Classified Environment

12. Select from the primary sub-panel options below. *(in order of preference from top to bottom)*

*If specifying breaker panels, please include breaker amperage and number of poles. (220, 222, and 206)*

Sub-Panel Positions - 1-4

1. Reserve for transformer protection.

2.

3.

4.

Primary Combo-Box Examples

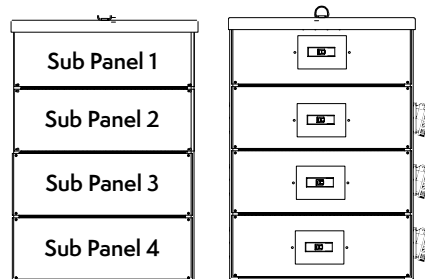

Primary Combo Box Sub-Panel Options

Panel 220

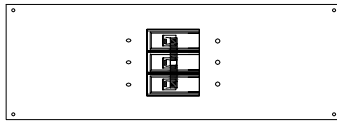

Main Breaker Panel  
3 Pole, 60-100A

Panel 222

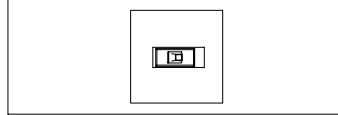

Main Breaker  
3 Pole, -125A-200A

Panel 209



Blank

Side or Panel Mounted Receptacle Options & Quantities

Enter configuration below.

IEC 309-2 Receptacle:

Metallic Pin & Sleeve:

Meltric:

IEC 309-2

Mechanical Interlocks:

Transformer:

Optional Primary Panel -

If you want a primary panel, please call Ericson manufacturing to discuss panel manufacturer, breaker sizes and positions with in the panel.

13. Specify transformer type (Dry-Type or Encapsulated) and kVA : \_\_\_\_\_

14. Specify Primary Voltage(s): \_\_\_\_\_

15. Specify Secondary Voltage(s): \_\_\_\_\_

16. Specify Secondary Receptacles or Pigtails: (See Page 28 for standard sub-panel options, or specify your own)

\_\_\_\_\_

# Design Your Own Secondary Combo Box™



## Combo-Box Enclosure Examples

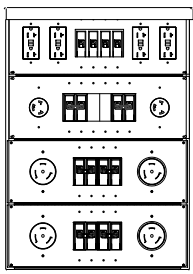

MLO

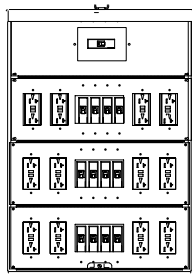

MCB

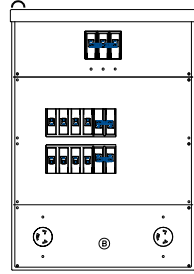

MCB & GFCI Breakers for Pigtails

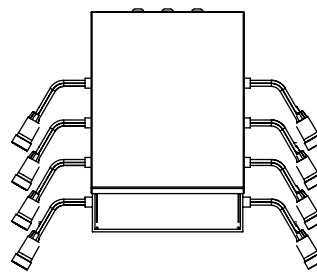

MCB with Pigtails  
*Pigtails Shown*

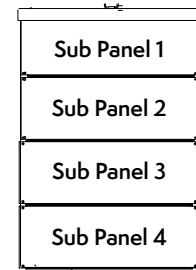

## Build Your Own Combo Box from Sub Panel Options Below

# Design Your Own Secondary Combo Box\*

Enter Options

Voltage	Amperage	Input	Main Feed	Output	Enclosure	Sub Panels	Mounting
12 = 120/240 18 = 120/208Y 47 = 277/480Y 60 = 600V	6 = 60 8 = 80 10 = 100 12 = 125 150 = 150 200 = 200	CAM = Cam Connectors IEC = IEC Inlet (specify amperage) CB = Cable, Blunt End CP = Cable with Plug (specify plug type)	MB = Main Breaker MLO = Main Lugs Only	CAM = Cam Receptacles IEC = IEC Receptacle REC = Receptacle – specify configuration	PCS = Powder Coated Steel SS = Stainless Steel	1. 2. 3. 4.	2W = Two Wheel Cart WM = Wall Mount

\* Assemble your custom secondary combo box with sub panel options below, and on page 30.

## Main Breaker Panels (Optional)

Panel 220

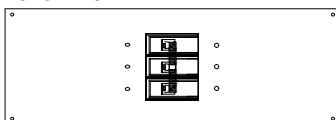

Main Breaker Panel  
3 Pole, 60-100A

Panel 222

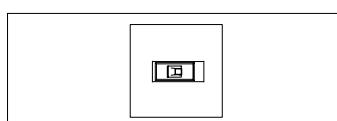

Main Breaker  
3 Pole, -125A-200A

Panel 206

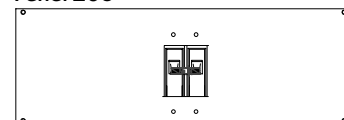

Main Breaker  
2 Pole, -60A-100A

# Design Your Own Secondary Combo Box™



## Combo-Box Enclosure Examples

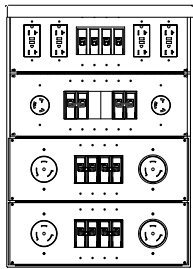

MLO

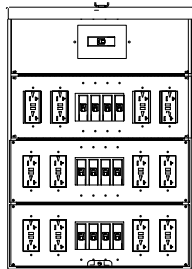

MCB

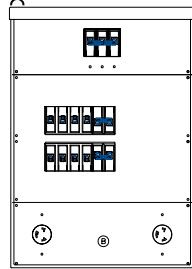

MCB & GFCI Breakers for Pigtails

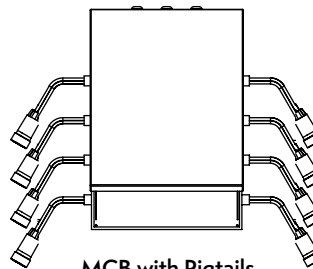

MCB with Pigtails  
*Pigtails Shown*

## Build Your Own Combo Box from Sub Panel Options Below\*

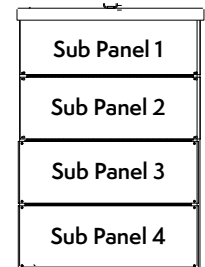

\*Please enter options on table on page 29.

## Receptacle Panels

Panel 362

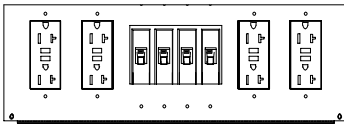

4 – 20A GFCI or Rectangular Receptacles, individually protected by 4 – 1P 20A Breakers

Panel 361

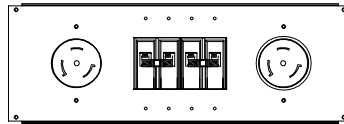

2 – 50A 2P-3W 125/250V receptacles individually protected by 2 – 2P 50A Breakers

Panel 364

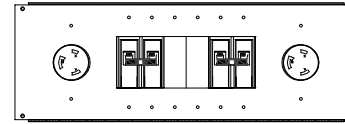

2 – 20A or 30A 2P/3W or 4P/5W receptacles individually protected by appropriately sized 2P or 3P breakers

Panel 363

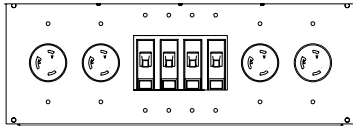

4 – 20A or 30A 2P/3W Single Phase Locking Receptacles with individual, appropriate sized 1P breakers

Panel 202-1

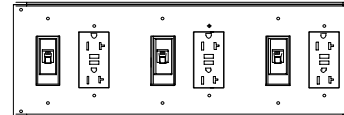

1 – 3 – 20A GFCI Receptacles, individually protected by 4 – 1P 20A Breakers

Panel 217

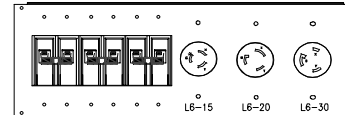

3 – 20 or 30A 2P/3W Single Phase Locking Receptacles with individual appropriately sized 2P breakers

Panel 225

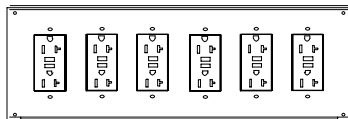

4 – 20A GFCI or Rectangular Receptacles, individually protected on a separate sub panel (see panel 213)

Panel 223

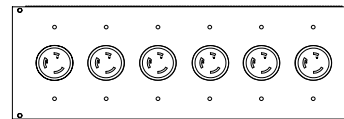

6 – 20 or 30A 2P/3W Single Phase Locking Receptacles, individually protected on a separate sub panel (see panel 213)

Panel 213

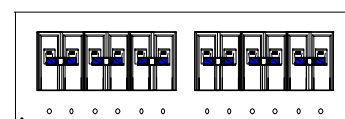

6 – Double Pole Breakers or 12 Single Pole Breakers

Panel 218

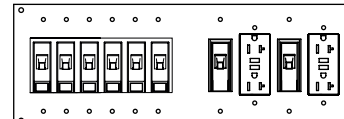

Blank



# Specific Applications Designs



Custom 2 Wheel Stainless Steel



Custom Skid CAM Input



Custom Shipyard Design



Custom T-Frame

## Trailerable Hazardous Location Design



## Wall Mounted Power Center



## Trailerable PTU Design



## Custom Dual Secondary IEC Pin & Sleeve Design



## 60A PDU Welding Cart





**Custom Power Center**



**Custom Portable Panel Designs**







# Related Products

Click on an image or scan the QR Code for more product information.



**PPB**

800-Amp Portable Panel Board



**PPB**

200-Amp Portable Panel Board



**PDC**

60-200-Amp Power Distribution Centers



**NM3 - Nonmetallic**

100-300-Amp Power Distribution Centers



**1066-FS**

50-Amp Power Distribution Unit



**CDU**

50-Amp Power Distribution Unit



**NM3 - Nonmetallic**

50-Amp Power Distribution Unit



**CDU-NM**

20-30-Amp Power Distribution Units



Factory Assembled Cordsets



**50 Amp**

California Style Plugs & Connectors

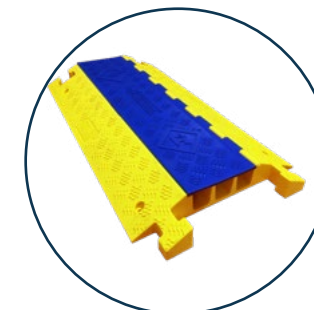

**Tufftraxx**

Cable & Hose Protection

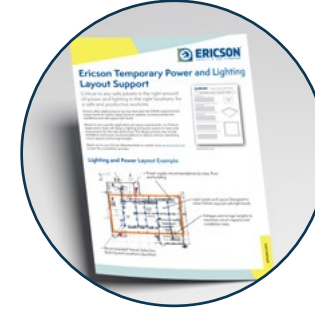

Custom Jobsite Lighting Layout Form



**1006**

100-150-Watt LED Baylight

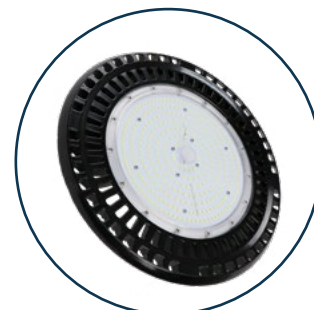

**1004**

100-150-Watt LED Highbay



**1009**

100-150-Watt LED Class 1, Div 2 Flood



**1007**

100-150-Watt LED Class 1, Div 1 Highbay



4323 Hamann Parkway  
Willoughby, OH 44094  
info@ericson.com  
ericson.com  
1.800.ERICSON  
L1000915B